

NOTE: THE INFORMATION CONTAINED IN THIS DRAWING IS THE SOLE PROPERTY OF PURLIN AUTOMATION INDIA PVT. LTD.
 ANY REPRODUCTION IN THE PART OR AS A WHOLE WITHOUT THE WRITTEN PERMISSION OF PURLIN AUTOMATION
 INDIA PVT. LTD. IS PROHIBITED.

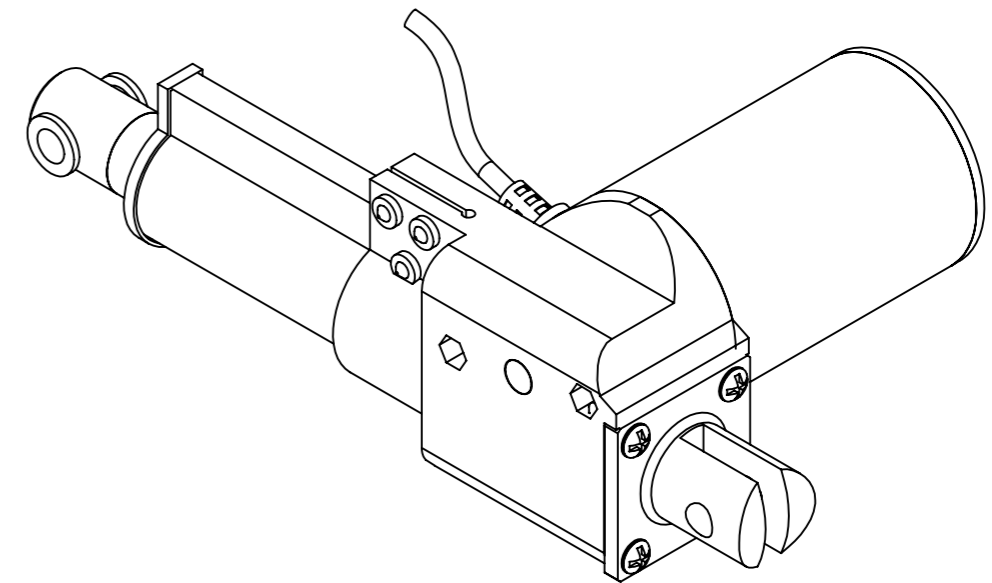
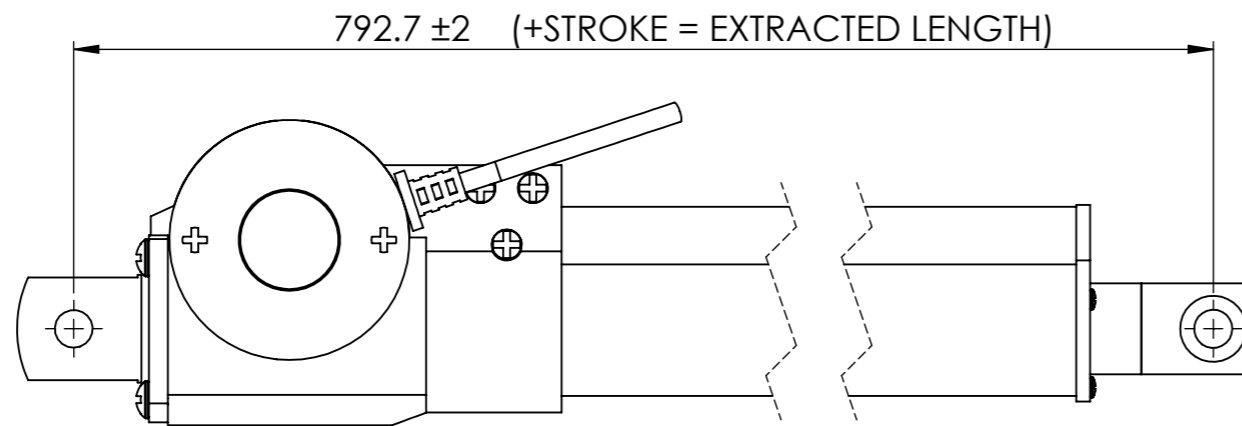
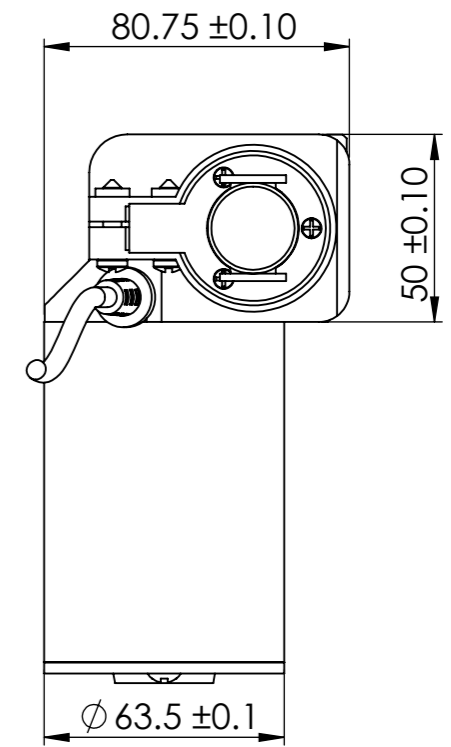
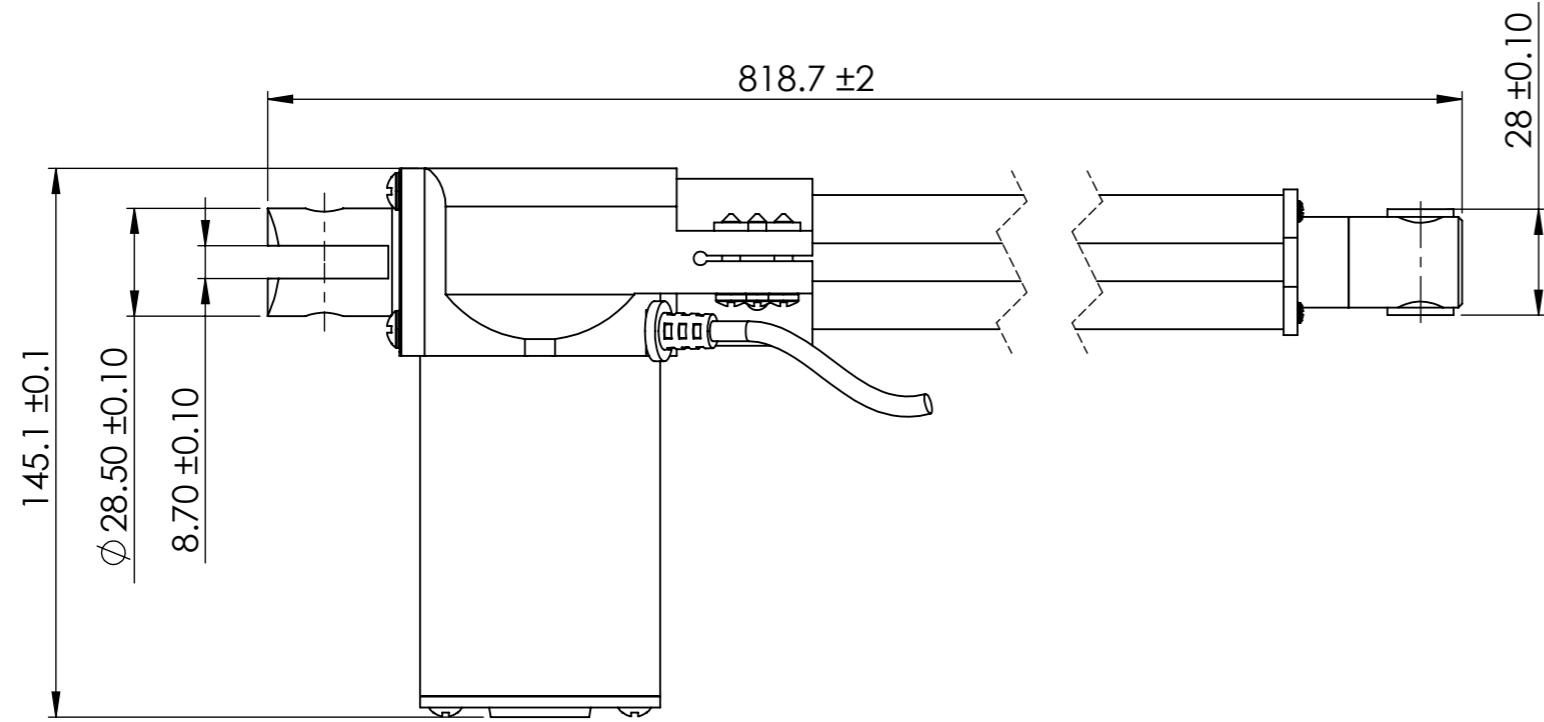

ISOMETRIC VIEW

TECHNICAL SPECIFICATION

STROKE : GIVEN IN TITLE BLOCK
 RETRACTED LENGTH : 192.7+ STROKE LENGTH
 EXTRACTED LENGTH : 192.7 + (2X STROKE LENGTH)
 LOAD CAPACITY : 4000N TO 8000N
 SPEED : 3mm/sec TO 12mm/sec
 INPUT VOLTAGE : 12 TO 24 VDC

FOR MORE INFORMATION PLEASE REFER OUR CATALOGUE

UNLESS OTHERWISE SPECIFIED: DIMENSIONS ARE IN MILLIMETERS SURFACE FINISH: TOLERANCES: LINEAR: ANGULAR:				FINISH:		DEBUR AND BREAK SHARP EDGES		DO NOT SCALE DRAWING		REVISION	
								PURLIN AUTOMATION INDIA PVT. LTD.			
								DISCRIPTION :			
								STROKE LENGTH 600MM			
DRAWN				NAME		SIGNATURE		DATE		DWG NO.	
CHK'D										PAI01V1	
APPV'D										A3	
MFG										SCALE:1:2	
Q.A										SHEET 1 OF 1	
								WEIGHT:			